

ORTAL

THREE SIDED FIREPLACES:

SPECIFICATIONS & PRODUCT GUIDE

ORTAL

ebnicca

1. NOTES

The appliance must be installed in accordance with the ORTAL AU/NZ Installation Manual.

The appliance must be properly connected to an approved chimney venting system. Refer to the specific appliance installation guide to determine vent size and pathway requirements. In addition, adhere to the following pre-installation guidelines:

- Use an approved DuraVent flue system as specified
- Consult the relevant authority to determine the need for a permit prior to starting the installation.
- It is the responsibility of the installer to ensure that this fireplace is installed in compliance with the manufacturer's instructions and all the applicable building codes. Contact your local distributor / dealer for correct flue and flue termination information.
- Always used a licensed gas fitter / plumber to install the appliance

IMPORTANT:

THIS IS NOT AN INSTALLATION MANUAL. PLEASE REFER TO THE DETAILED INSTALLATION MANUAL DELIVERED WITH THE APPLIANCE.

2. SPECIFICATIONS

MODEL	BURNER TYPE	INJECTORS	NOMINAL GAS CONSUMPTION	INLET PRESSURE	MANIFOLD PRESSURE	TURNDOWN PRESSURE	FLUE SIZE
75	B45	Marked 650: with 7x0.950mm orifice	26MJ/h	1.13kPA	0.82kPA	0.23kPA	107/164mm
110 / 110H	B100	Marked 1200: with 7x1.275mm orifice	37MJ/h	0.69kPA	0.73kPA	0.26kPA	125/205mm
130 / 130H	B100	Marked 1200: with 7x1.275mm orifice	37MJ/h	0.69kPA	0.73kPA	0.26kPA	125/205mm
150 / 150H	B135	Marked 1200: with 7x1.275mm orifice Marked 1400: with single 3.9mm orifice	55MJ/h	1.13kPA	0.61kPA	0.22kPA	125/205mm
170 / 170H	B135	Marked 1200: with 7x1.275mm orifice Marked 1400: with single 3.9mm orifice	55MJ/h	1.13kPA	0.61kPA	0.22kPA	125/205mm
200 / 200H	B160	Marked 800: with 7x1.05mm orifice Marked 1400: with single 3.8mm orifice	52MJ/h	1.13kPA	0.50kPA	0.22kPA	125/205mm
250 / 250H	B160	Marked 800: with 7x1.05mm orifice Marked 1400: with single 3.8mm orifice	52MJ/h	1.13kPA	0.50kPA	0.22kPA	125/205mm

3. DIMENSIONS

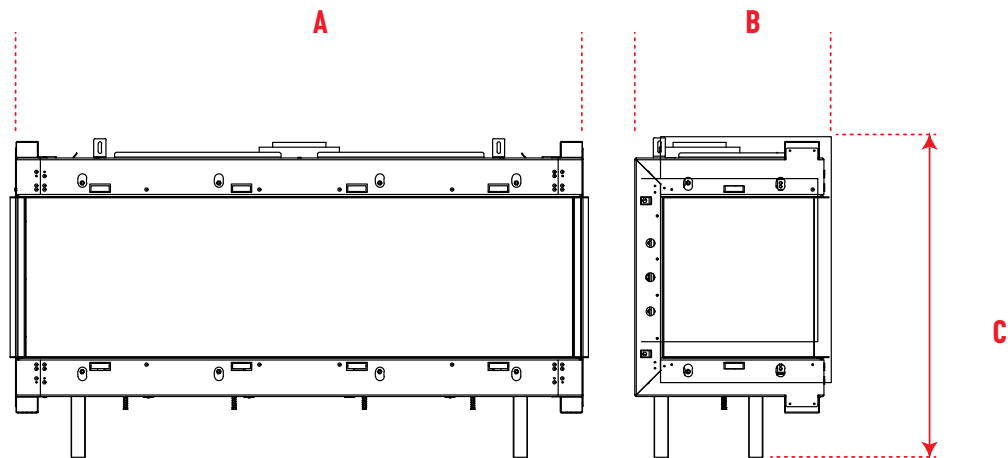

MODEL (all measurements in mm)	A WIDTH	B DEPTH	C HEIGHT	GLASS SIZE FRONT W×H	GLASS SIZE SIDE W×H
75 TS	878	472	804	878 x 480	411 x 480
110 TS	1268	484	742	1268 x 400	413 x 400
110 H TS	1268	528	742	1243 x 515	413 x 550
130 TS	1438	484	742	1438 x 400	413 x 400
130 H TS	1438	528	928	1438 x 515	413 x 550
150 TS	1688	484	742	1688 x 400	413 x 400
150 H TS	1688	528	928	1688 x 515	413 x 550
170 TS	1888	484	742	1888 x 400	413 x 400
170 H TS	1888	528	888	1888 x 550	413 x 550
200 TS	2128	484	742	2128 x 400	413 x 400
200 H TS	2128	528	928	2128 x 550	413 x 550
250 TS	2628	484	742	2628 x 400	413 x 400
250 H TS	2628	528	928	2628 x 550	413 x 550

Note: Minimum height off of the floor for all front facing Ortal fireplaces is 210mm.
Appliance legs must not be removed.

4. FRAMING & CLADDING

OPTION 1: METAL STUDS FRAMING

The frame must be designed to carry the entire weight of the finished wall with no component being supported by the fireplace.

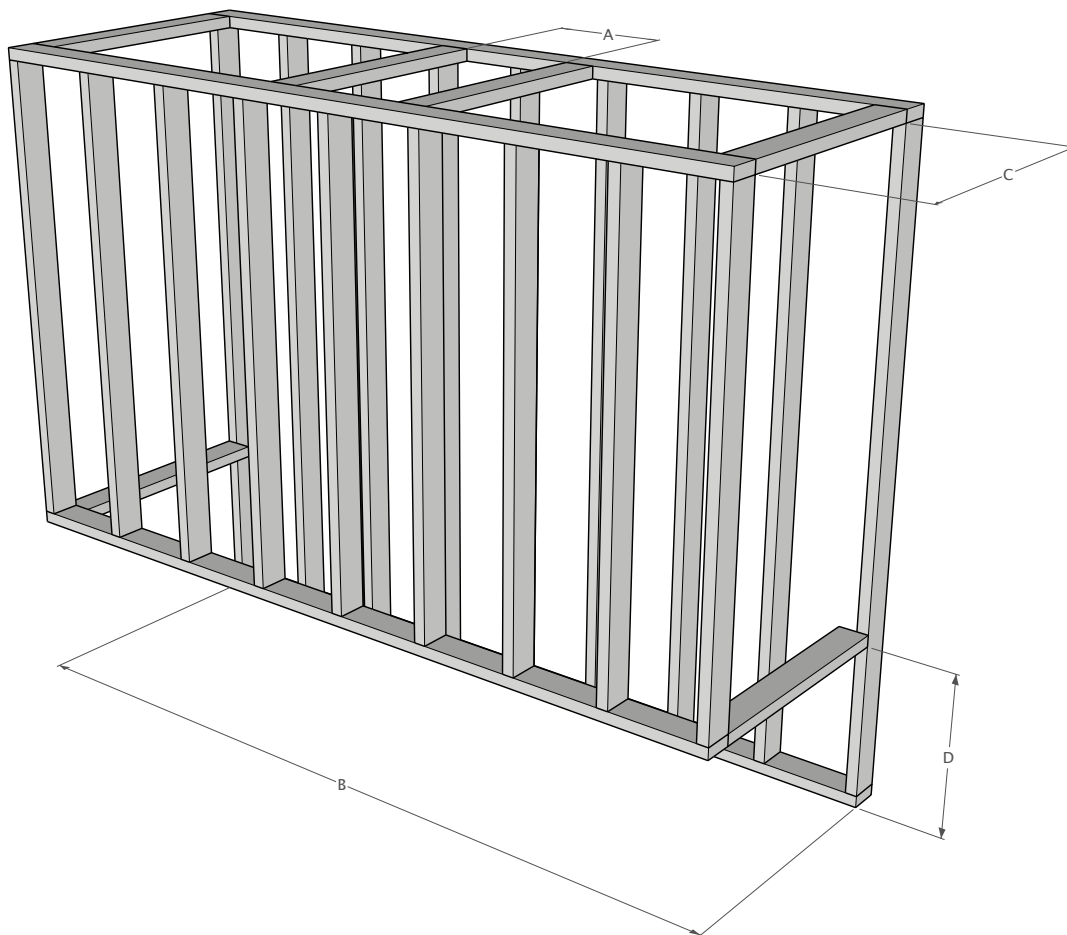

MODEL (all measurements in mm)	A	B	C	D
75	222	853	525	826
110	254	1243	538	764
110H	254	1243	581	861
130	254	1413	538	764
130H	254	1413	581	861
150	254	1662	538	764
150H	254	1662	581	861
170	254	1862	538	764
170H	254	1862	581	861
200	254	2102	538	764
200H	254	2102	581	861
250	254	2602	538	764
250H	254	2602	581	861

CLADDING FOR METAL STUDS

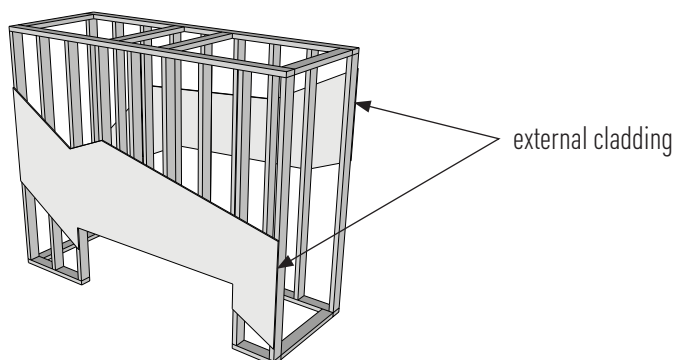

The framing structure must be clad **externally** with non combustible material and gaps sealed with a non-combustible fire proof sealant. We recommend the fireplace to be in position and flued prior to cladding.

4. FRAMING & CLADDING

OPTION 2: TIMBER STUDS WITH METAL SECTION

The frame must be designed to carry the entire weight of the finished wall with no component being supported by the fireplace.

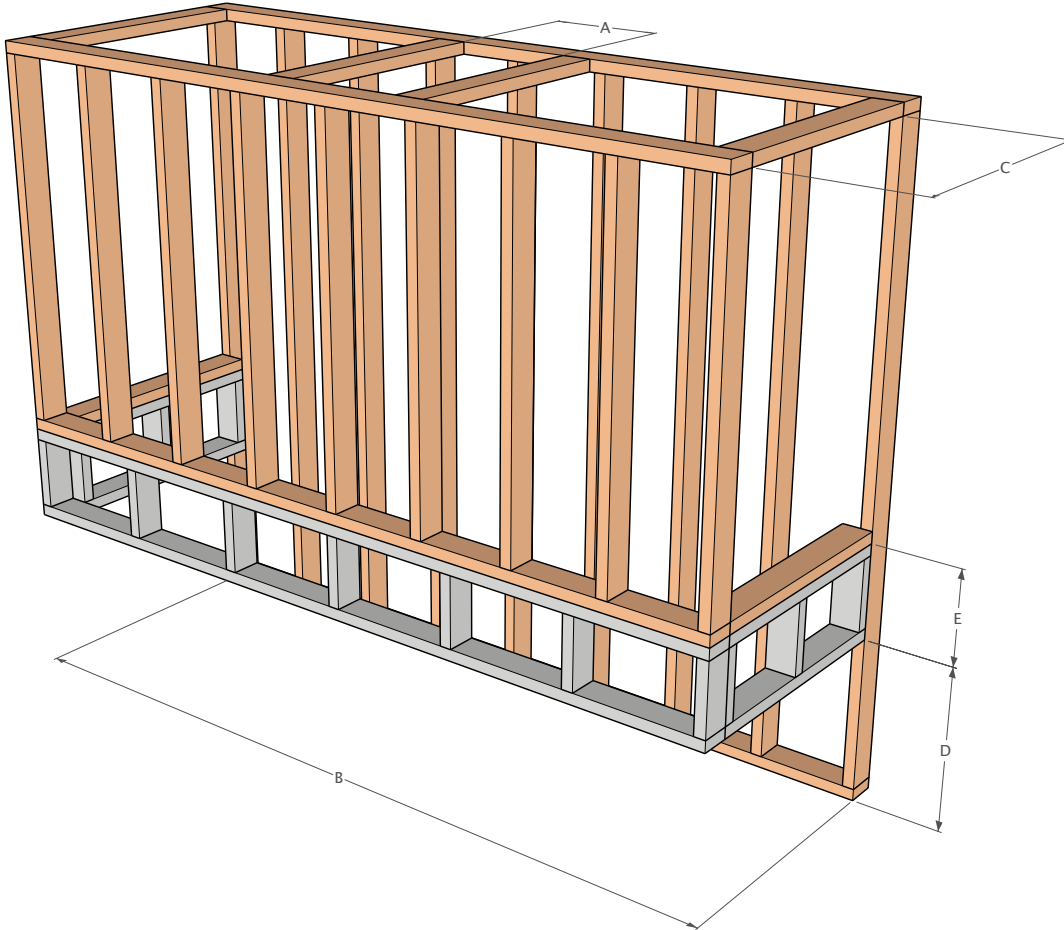

MODEL (all measurements in mm)	A	B	C	D	E
75	222	853	525	826	457
110	254	1243	538	764	519
110H	254	1243	581	861	549
130	254	1413	538	764	519
130H	254	1413	581	861	549
150	254	1662	538	764	519
150H	254	1662	581	861	549
170	254	1862	538	764	519
170H	254	1862	581	861	549
200	254	2102	538	764	519
200H	254	2102	581	861	549
250	254	2602	538	764	519
250H	254	2602	581	861	549

CLADDING FOR TIMBER STUDS WITH METAL SECTION

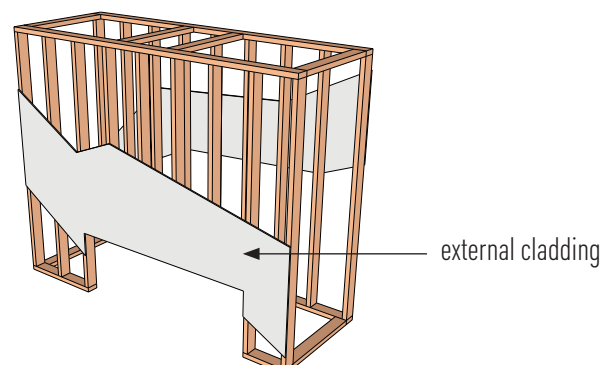

The framing structure must be clad **externally** with non combustible material and gaps sealed with a non-combustible fire proof sealant. We recommend the fireplace to be in position and flued prior to framing/cladding.

We recommend using 16mm Gypsum fire rated plasterboard or its equivalent for the enclosure of the fireplace chase.

5. VENTING

VENTING (convection air intake)

For mesh units:

- No need to create a convection air intake as the appliance is designed to supply fresh air through the viewing panel.

For double glass units:

- Convection air intake vents are required at the bottom of the cavity and can be placed at the front, side or back of the cavity.

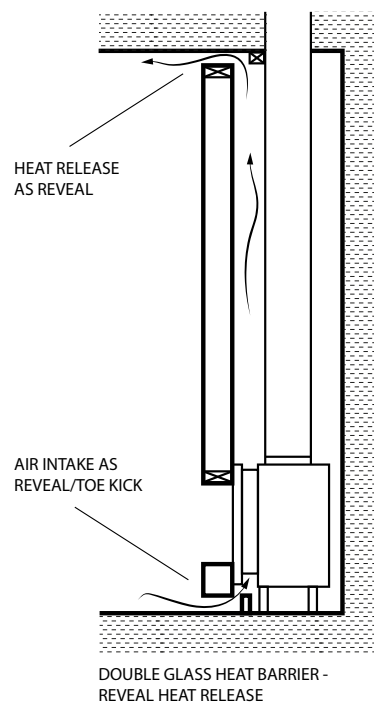
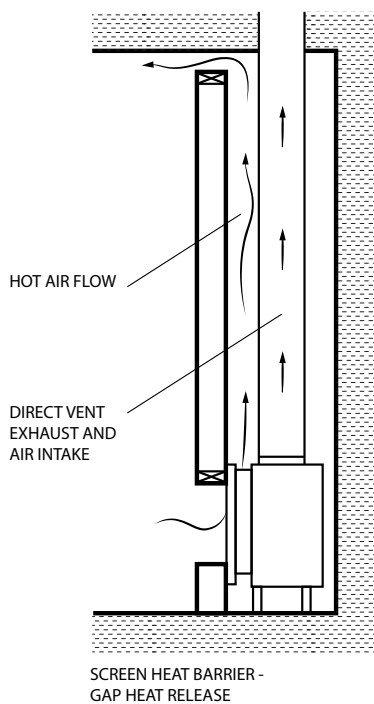

VENTING (Convection air outlet)

A convection air outlet is required for all Ortal fireplaces. This allows for heat building up within the fireplace cavity to be released back into the space, helping to keep the cavity walls cool. It must be located at the top of the fireplace cavity and be placed at a maximum of 150mm below the cavity ceiling. The vent can be located on the front, sides or back of the fireplace cavity, as long as it releases into an interior space and not outdoors.

MODEL	Heat release vent (min surface)
60 to 130	0.08m ²
150 to 200	0.13m ²
250	0.16m ²

These are minimum requirements and the surface can be greater if desired.

6. ACCESS PANEL

Access panels are recommended for all ORTAL fireplaces. They allow efficient and comfortable access to the fireplace receiver and valves, which is required for servicing purposes.

Access panels can be designed and positioned to minimise their visual impact as long as access to the valves and receiver is maintained. The size of the access panel may vary, but in all cases must allow the fireplace technician to effectively conduct a service. We recommend a minimum size of 200x200mm.

However, access panels are not the only option for servicing the fireplace operation mechanisms. A technician may also service the fireplace controls by going through the firebox. This procedure requires removing the glass panel(s), taking out the interior media and lifting the grill, burner and bottom side (explosion valve) of the unit. The technician would then return all these fireplace components when service is complete. The servicing procedure will take longer than through an access panel.

Fireplace installers are advised to consult with their clients, project architects or interior designers regarding the advantages and disadvantages of each service option.

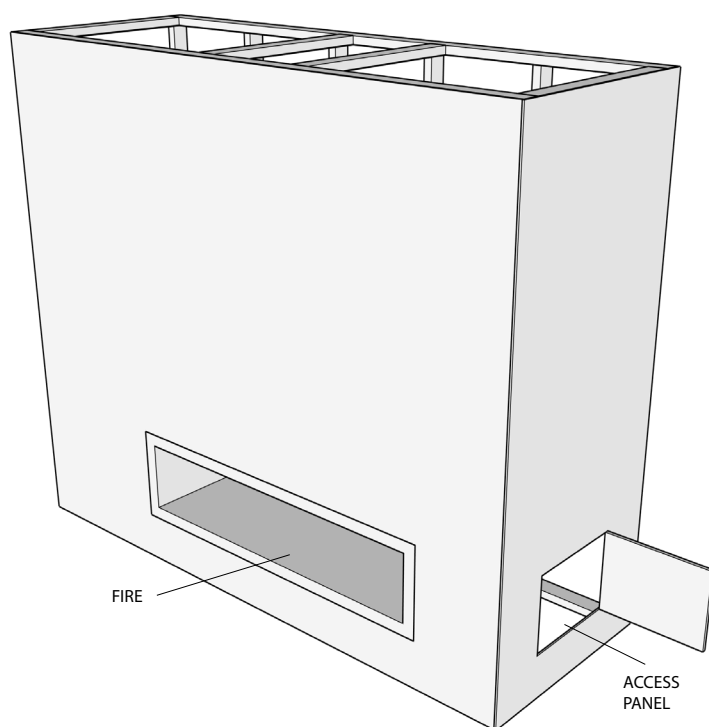

7. TV CLEARANCES

RECESSED INSTALLATION

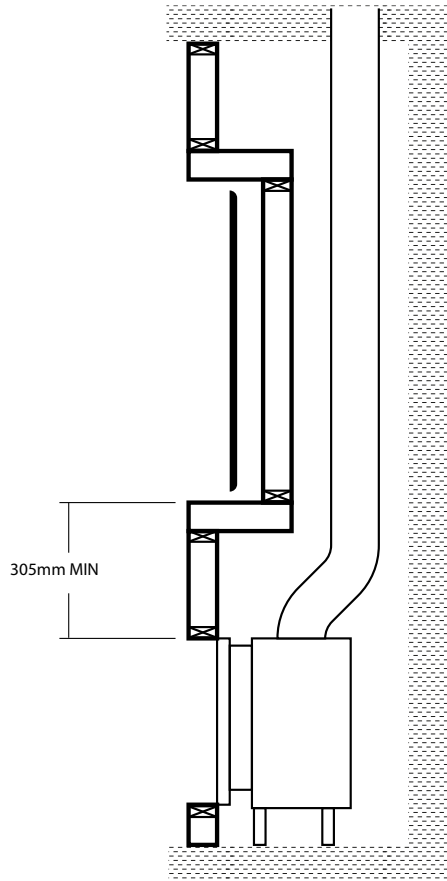

FLUSH INSTALLATION

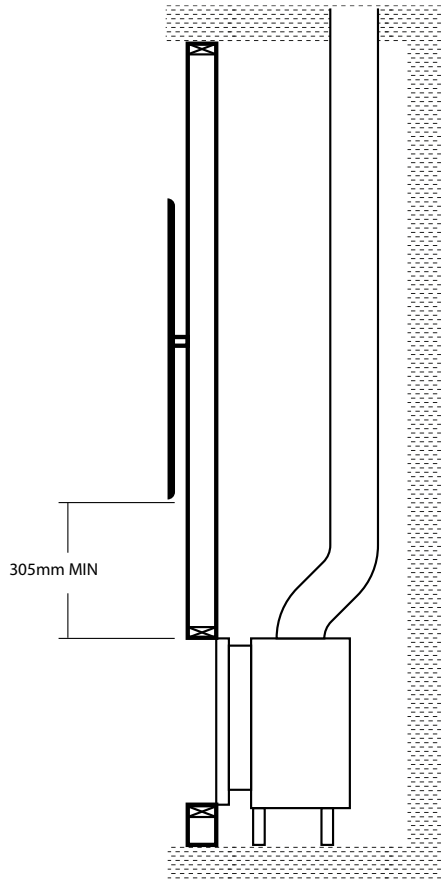

8. TESTING

THE ORTAL DECORATIVE ROOM SEALED GAS APPLIANCES HAVE BEEN TESTED AND APPROVED BY AGA & IAPMO-R&T FOR USE WITH NATURAL GAS (NG).

Australian Standard AS5263-0:2016 - Decorative Gas Log and Other Fuel Effect Appliances

Patent Pending for screen barrier glass bracket: USSN 60/040,074